

EI 45 MINI

0,54

U_d VALUE
(W/m² * K)



MAXIMUM
LOAD



SEAL



FIRE RESISTANT
SEAL



PROTECTIVE
FEET



HATCH
THICKNESS



HANDRAIL



YEARS
GUARANTEE



COMPLIANCE WITH
THE STANDARD

OMAN[®]



EI 45 MINI

The **MINI EI45** loft ladder features triple sealing, including a single fire seal and a 66mm thick hatch. The **MINI EI 45** loft ladder has a fire resistance class - **EI45**. The **MINI EI45** loft ladder model is ideal for installation in rooms particularly exposed to the outbreak of fire, its fire resistant properties will effectively isolate the room in which the fire occurs from the loft, thus preventing further spread of fire. The staircase has non-slip feet that adhere perfectly to the floor, prevent scratching of the floor surface and provide an aesthetically pleasing finish to the ladder after it has been cut. For increased safety and comfort of use, the **EI45** stairs are equipped with a stable and durable handrail. For the user's convenience, the handrail has been designed in such a way that it can be installed on the left or right side, depending on the customer's preference. The excellent quality of materials used in the production of the stairs, as well as attention to every detail of the finish ensure that the stairs will satisfy even the most demanding customers, and their maximum load during use is up to 160 kg.

Technical specification

INSULATED HATCH THICKNESS	66 mm
THICKNESS OF THERMAL INSULATION	60 mm
HATCH COLOUR FROM BOTH SIDES	white
METAL-WOODEN LADDER	4 sections
HEIGHT OF WOODEN BOX	170 mm
WIDTH OF LADDER	365 mm
WIDTH OF STEP	324 mm
DEPTH OF STEP	80 mm
MAXIMAL LANDING SPACE	130 cm
OPENING DISTANCE	125 cm
MAXIMUM CEILING HEIGHT	265 cm

Box dimensions [cm] A x B

Outer box dimensions, mounting opening 2 cm longer.

90 x 60	100 x 60
90 x 70	100 x 70

Technical drawing

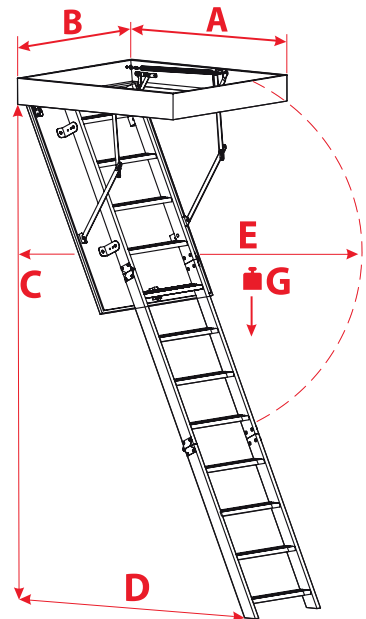

C	265 cm
D	130 cm
E	125 cm
G	160 kg

Accessories

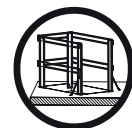

HATCH
BALUSTRADE