

# EI 45

0,54

**U<sub>d</sub> VALUE**  
(W/m<sup>2</sup> \* K)



MAXIMUM  
LOAD



SEAL



FIRE RESISTANT  
SEAL



PROTECTIVE  
FEET



HATCH  
THICKNESS



HANDRAIL



YEARS  
GUARANTEE



COMPLIANCE WITH  
THE STANDARD

**OMAN**<sup>®</sup>



# EI 45

The **EI45** loft ladder features triple sealing, including a single fire seal and a 66mm thick hatch. The **EI 45** loft ladder has a fire resistance class - **EI45**. The **EI45** model of the staircase is ideal for installation in rooms particularly prone to the outbreak of fire, its fire resistant properties will effectively isolate the room in which the fire occurs from the loft, thus preventing further spread of fire. The staircase has non-slip feet that adhere perfectly to the floor, prevent scratching of the floor surface and provide an aesthetically pleasing finish to the ladder after it has been cut. For increased safety and comfort of use, the **EI45** stairs are equipped with a stable and durable handrail. For the user's convenience, the handrail has been designed in such a way that it can be installed on the left or right side, depending on the customer's preference. The excellent quality of materials used in the production of the stairs, as well as attention to every detail of the finish ensure that the stairs will satisfy even the most demanding customers, and their maximum load during use is up to 160 kg.

## Technical specification

INSULATED HATCH THICKNESS	66 mm
THICKNESS OF THERMAL INSULATION	60 mm
HATCH COLOUR FROM BOTH SIDES	white
METAL-WOODEN LADDER	3 sections
HEIGHT OF WOODEN BOX	170 mm
WIDTH OF LADDER	400 mm
WIDTH OF STEP	358 mm
DEPTH OF STEP	80 mm
MAXIMAL LANDING SPACE	145 cm
OPENING DISTANCE	168 cm
MAXIMUM CEILING HEIGHT	280 cm

## Box dimensions [cm] A x B

Outer box dimensions, mounting opening 2 cm longer.

120 x 60	130 x 60
120 x 70	130 x 70

## Technical drawing

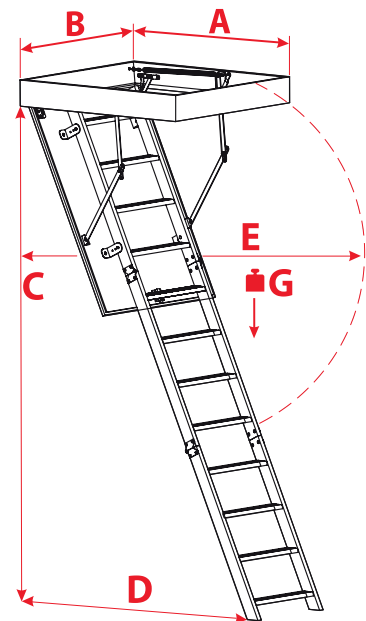

C	280 cm
D	145 cm
E	168 cm
G	160 kg

## Accessories

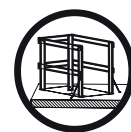

HATCH  
BALUSTRADE