

MINI EXTRA

0,85

U_d VALUE
(W/m² * K)



MAXIMUM
LOAD



PROTECTIVE
FEET



SEAL



HANDRAIL



HATCH
THICKNESS



YEARS
GUARANTEE



COMPLIANCE WITH
THE STANDARD

OMAN[®]



MINI EXTRA

The **MINI EXTRA** loft ladder features a single seal and a 46mm thick hatch. The **MINI EXTRA** model is ideal for conditions where the loft is poorly insulated and requires additional thermal insulation. The small size of the MINI staircase is ideal for installation in narrow and small corridors. The staircase is equipped with non-slip feet that perfectly adhere to the floor, prevent scratching of the floor surface and provide an aesthetic finish to the ladder after it has been cut. For increased safety and comfort of use, the **MINI EXTRA** stairs have been equipped with a stable and durable handrail. With the user's comfort in mind, the handrail has been designed so that it can be installed on the left or right side, depending on the customer's preference. The excellent quality of materials used in the production of the stairs and attention to every detail of the finish ensure that the stairs will satisfy even the most demanding customers, and their maximum load during use is up to 160 kg.

Technical specification

INSULATED HATCH THICKNESS	46 mm
THICKNESS OF THERMAL INSULATION	40 mm
HATCH COLOUR FROM BOTH SIDES	white
WOODEN LADDER	4 sections
HEIGHT OF WOODEN BOX	170 mm
WIDTH OF LADDER	365 mm
WIDTH OF STEP	324 mm
DEPTH OF STEP	80 mm
MAXIMAL LANDING SPACE	130 cm
OPENING DISTANCE	125 cm
MAXIMUM CEILING HEIGHT	265 cm

Box dimensions [cm] A x B

Outer box dimensions, mounting opening 2 cm longer.

80 x 60	90 x 60	100 x 60
80 x 70	90 x 70	100 x 70

Non-standard dimensions

Min - Max Length	80 - 100 cm
Min - Max Width	60 - 80 cm

*Unusual dimensions available in full size of untypical stairs can not exceed 1 m².

Technical drawing

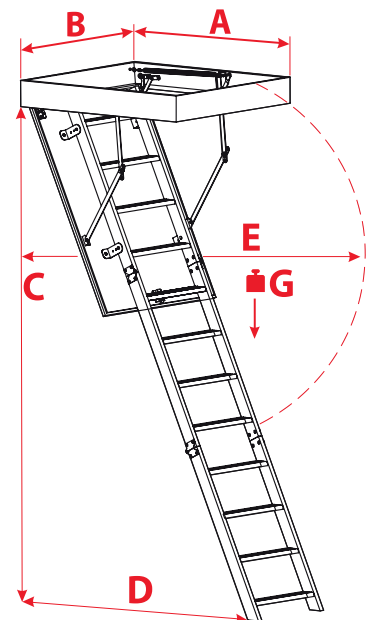

A > 90

C	265 cm
D	130 cm
E	125 cm
G	160 kg

A < 90

C	260 cm
D	103 cm
E	120 cm
G	160 kg

Accessories



MASKING BATTEN



MOUNTING SYSTEM



HATCH BALUSTRADE