

MINI POLAR

0,36

U_a VALUE
(W/m² * K)



MAXIMUM
LOAD



PROTECTIVE
FEET



SEAL



HANDRAIL



ADDITIONAL
STEP



YEARS
GUARANTEE



HATCH
THICKNESS

4 CLASS
AIR
TIGHT
NESS



COMPLIANCE WITH
THE STANDARD

OMAN[®]



MINI POLAR

The **MINI POLAR** staircase features double sealing and an 86 mm thick hatch, which makes it perfect for any conditions, while at the same time contributing to a significant reduction in costs associated with heating your home or flat. The **MINI POLAR** staircase features the best heat transfer coefficient on the market of $U=0.36$ and the highest airtightness class 4. Due to its excellent parameters, the **MINI POLAR** staircase is ideal for installation in places where large temperature differences occur. Choosing the **MINI POLAR** staircase is an investment which allows you to reduce the loss of heated air, improve the level of thermal insulation and significantly reduce heating costs. The **MINI POLAR** staircase is equipped with anti-slip feet that perfectly adhere to the floor, prevent scratching of the floor surface and provide aesthetic finish of the ladder after it has been cut. The **MINI POLAR** stairs are equipped with a stable and durable handrail for increased safety and comfort of use. The excellent quality of materials used in the production of the stairs and attention to every detail of finishing ensure that the stairs will satisfy even the most demanding customers, and their maximum load during use is up to 160 kg. By choosing the best insulated loft ladder on the market, you reduce heating costs and thus make a real contribution to the fight for a better climate.

Technical specification

INSULATED HATCH THICKNESS	86 mm
THICKNESS OF THERMAL INSULATION	80 mm
HATCH COLOUR FROM BOTH SIDES	white
WOODEN LADDER	4 sections
HEIGHT OF WOODEN BOX	170 mm
WIDTH OF LADDER	365 mm
WIDTH OF STEP	324 mm
DEPTH OF STEP	80 mm
MAXIMAL LANDING SPACE	149 cm
OPENING DISTANCE	133 cm
MAXIMUM CEILING HEIGHT	265 cm

Box dimensions [cm] A x B

Outer box dimensions, mounting opening 2 cm longer.

90 x 50*	100 x 50*	110 x 50*
90 x 55	100 x 55	110 x 55
90 x 60	100 x 60	110 x 60
90 x 70	100 x 70	110 x 70

*replacing a handrail is unavailable

Non-standard dimensions

Min - Max Length	90 - 110 cm
Min - Max Width	50 - 80 cm

*Unusual dimensions available in full size of untypical stairs can not exceed 1 m².

Technical drawing

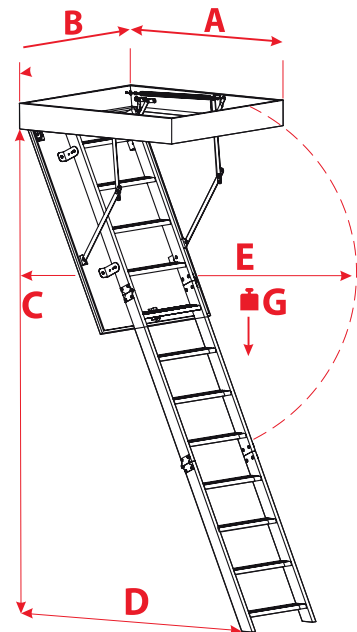

A > 100

C	265 cm
D	142 cm
E	133 cm
G	160 kg

A < 100

C	265 cm
D	149 cm
E	132 cm
G	160 kg

Accessories



MASKING BATTEN



MOUNTING SYSTEM



HATCH BALUSTRADE